



# Stock Package Options

Email us today for a FREE QUOTE  
814.878.4613 [gallab@plastekgroup.com](mailto:gallab@plastekgroup.com)

## Plastek Flip-Top Closures

These closures are injection molded components for bottles that require a screw on closure.

With a functional 2-in-1 secure closure and dispensing feature, this stock product design opens a variety of possibilities for our customers needing packaging for liquids or soft solids. Multiple markets include consumer products benefiting from these flip-top closures. Examples range from craft paints, hand sanitizers, and lotions, to dressings, condiments, and sauces.

For consumer experience, these caps feature a serrated/ ribbed circumference to aid in the opening and closing of the container. They are available in stock natural, white and black, but can be custom colored as required. Please contact us to request MOQ details.

### Technical Information

- △ Cap threads conform to SPI standards for 400 finish closures.
- △ Flip-Top Closures are made of polypropylene (PP).
- △ FDA approved resin.
- △ Design includes a living hinge. (Displayed below to show both open and closed).
  - The manufacturing process for the 24mm includes in-mold closing production of the flip-top feature. Finished 24mm Flip-Top molded parts are shipped closed.

#### 24mm Flip-Top

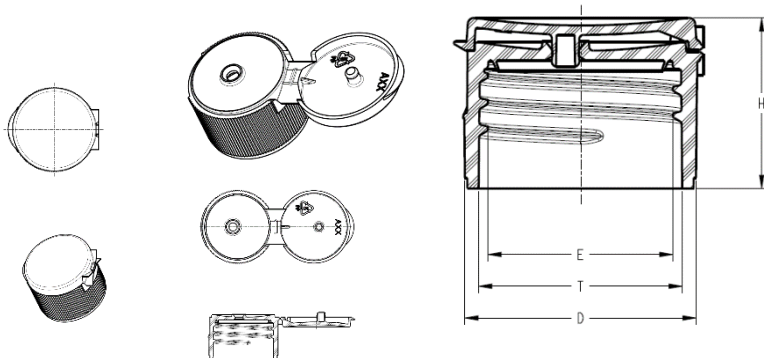

#### Dimensions (Inches)

Cap Size (mm)	Max. Cap Diameter D	Cap Height H	Cap Threads	
			T	E
<b>24mm Flip Top Cap</b>				
24	1.086	.805	.956	.868

#### 28mm Flip-Top

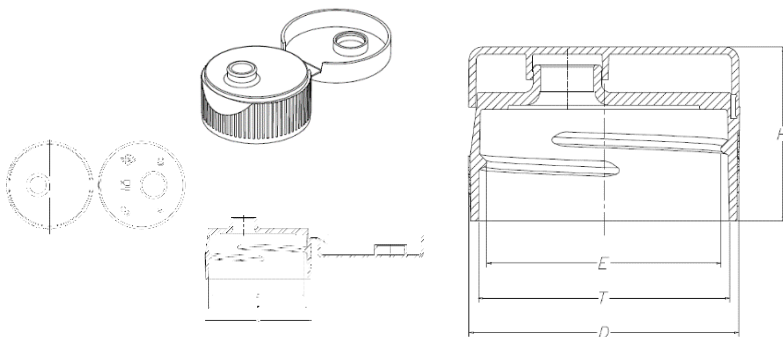

#### Dimensions (Inches)

Cap Size (mm)	Max. Cap Diameter D	Cap Height H	Cap Threads	
			T	E
<b>28mm Flip Top Cap</b>				
28	1.194	.768	1.110	1.035

Website: [www.plastekgroup.com](http://www.plastekgroup.com)

Email: [gallab@plastekgroup.com](mailto:gallab@plastekgroup.com)

Phone:

814.878.4613